

7132

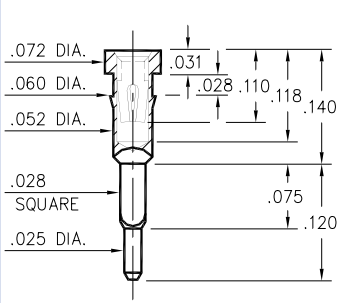

7132-0-15-XX-30-XX-04-0
Square press-fit for .032 ±.002 plated thru hole

8445

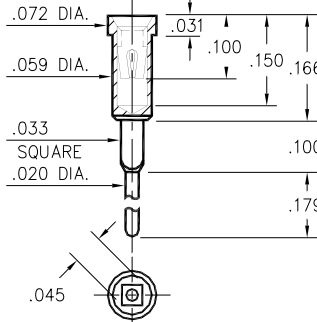

8445-0-15-XX-30-XX-04-0
Square press-fit for .039 ±.002 plated thru hole

1038

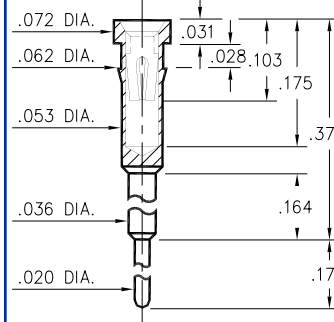

1038-0-15-XX-30-XX-04-0
Press-fit in .059 mounting hole

1261

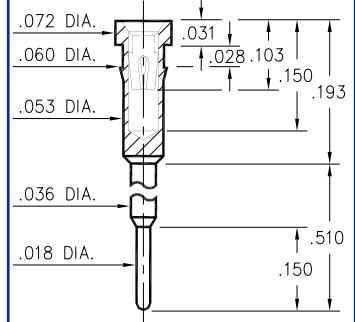

1261-0-15-XX-30-XX-04-0
Press-fit in .057 mounting hole

0153

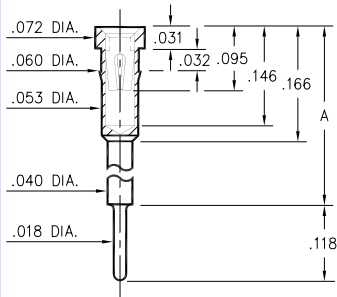

0153-X-15-XX-30-XX-04-0
Press-fit in .057 mounting hole

Basic Part Number	Height A
0153-1	.236
0153-2	.315
0153-3	.402
0153-4	.472
0153-5	.594
0153-6	.699

1602/1610

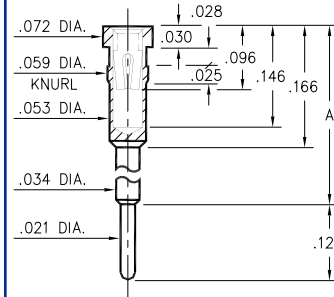

16XX-0-15-XX-30-XX-04-0
Press-fit in .057 mounting hole

Basic Part Number	Height A
1602-0	.441
1610-0	.642

0903/0904

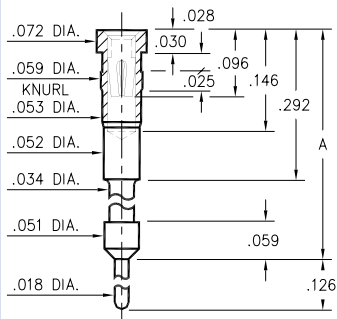

090X-0-15-XX-30-XX-04-0
Press-fit in .057 mounting hole

Basic Part Number	Height A
0903-0	.841
0904-0	1.141

0144

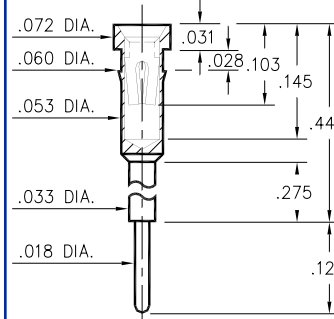

0144-0-15-XX-30-XX-04-0
Press-fit in .057 mounting hole

8252

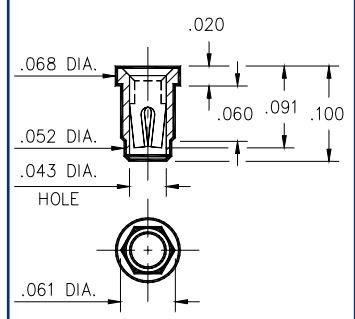

8252-0-15-XX-30-XX-10-0
Press-fit in .057 plated thru hole

SPECIFICATIONS

SHELL MATERIAL:
Brass Alloy 360, 1/2 Hard

CONTACT MATERIAL:
Beryllium Copper Alloy 172, HT

DIMENSION IN INCHES
TOLERANCES ON:
LENGTHS: ±.005
DIAMETERS: ±.002
ANGLES: ± 2°

ORDER CODE: XXXX - X - 15 - XX - 30 - XX - XX - 0

BASIC PART # →

SPECIFY SHELL FINISH: →

01 200μ" TIN/LEAD OVER NICKEL
15 10μ" GOLD OVER NICKEL

SPECIFY CONTACT FINISH: →

02 200μ" TIN/LEAD OVER NICKEL
14 10μ" GOLD OVER NICKEL
27 30μ" GOLD OVER NICKEL

SELECT CONTACT

#30 CONTACT (DATA ON PAGE 208)